

# PLAN 13

## Suction Recirculation

**What** Suction recirculation through an orifice to the flush port of the seal.

**Why** To vent the seal chamber area and/or to reduce the seal chamber pressure.

**When** Seal chamber pressure must be reduced to increase/improve seal life or when solids in the process are accumulating around the seal faces. Used for seal chamber venting in a vertical pump.

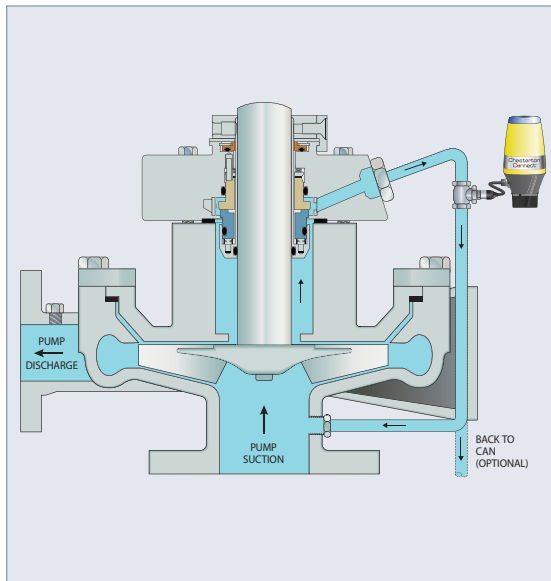

**KEY**

- 1 — To Pump Suction
- 2 — Flush (F)
- 3 — Quench/Drain (Q/D)
- 4 — Seal Chamber

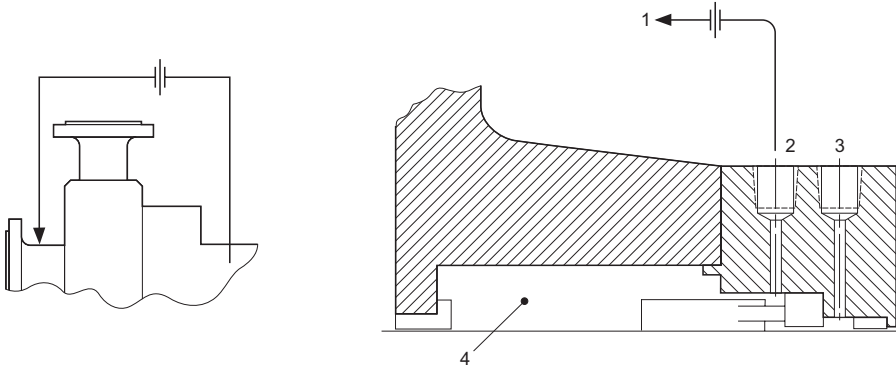

*Drawing reproduced from ANSI/API Standard 682, Third Edition, September 2004, courtesy of the American Petroleum Institute.*