

# 891/880 Component Seal Installation Instructions

Large Sizes 68 mm to 200 mm (2.750" to 8.000")

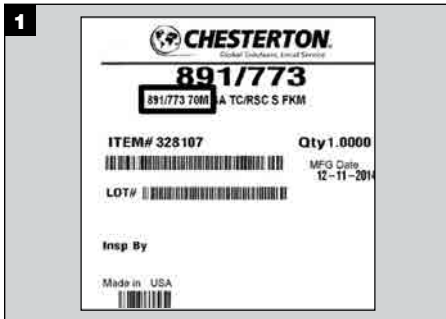

Refer to label for component identification and shaft diameter. Determine if the rotary unit is the short version (SH = short rotary).

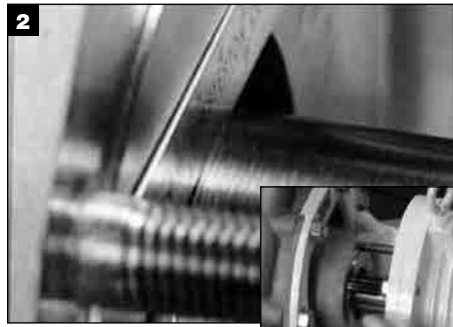

Refer to installation images on page 2 for reference points from which you will measure the installation dimension. Spray the shaft in the area of the reference point with layout fluid and mark the point.



Remove the seal housing from the equipment.

891 – METRIC (all dimensions are in millimeters)						
Shaft	714	719	723	777	725	755
68				48.9		
70		49.2		48.9		
75		55.5		55.3		
80		55.5		55.3		
85		55.5		55.3		
90		55.5		55.3		63.5
95				55.3		70.7
100	55.5			55.3		70.7
110				55.3		
120						
125						
130						

Determine dimension from tables on page 3 by matching the stationary model number with the shaft diameter found on the label. Calculate installation dimension from images on page 2.

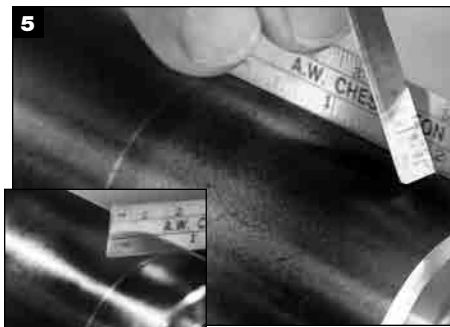

Spray layout fluid on the end of the shaft and measure and mark the installation dimension from the reference point.

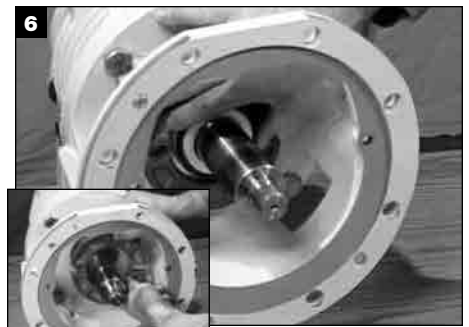

Slide the gland, then the stationary seal face over the shaft. Press fit the stationary seal face in the gland if it is O-Ring mounted.

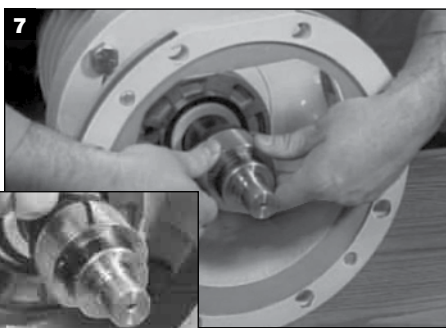

Apply a thin film of grease to the shaft O-Ring and slide rotary unit onto shaft so that back of unit is in line with measured scribe mark. Tighten all set screws evenly.

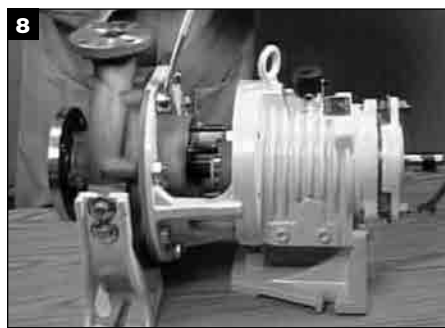

Re-assemble the seal housing (back cover) on to the equipment.



Insert stationary into gland and attach gland up to stuffing box face.

# INSTALLATION IMAGES

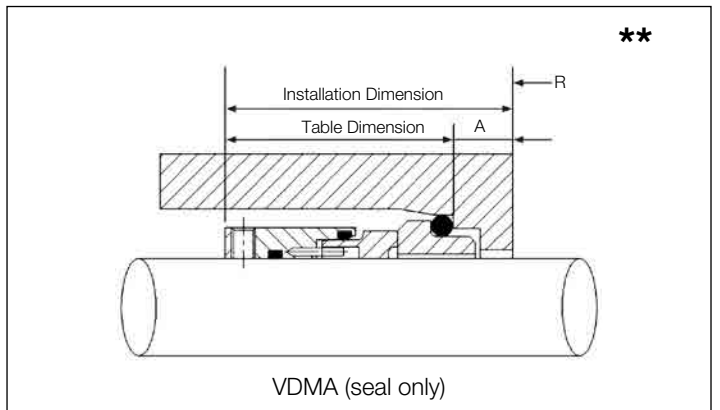
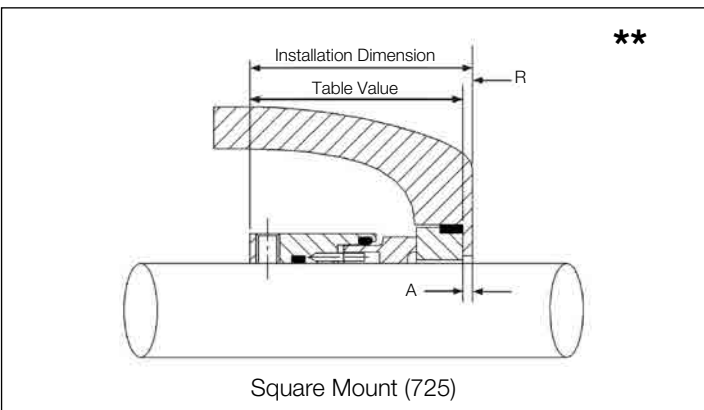
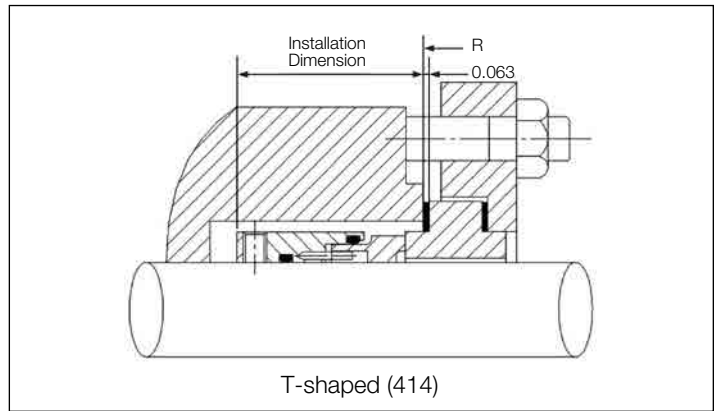
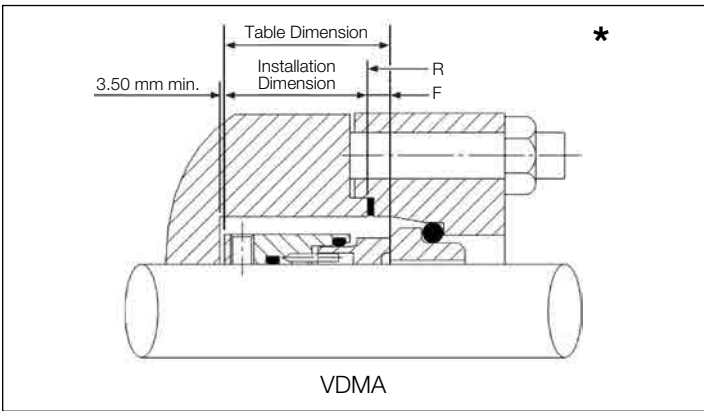
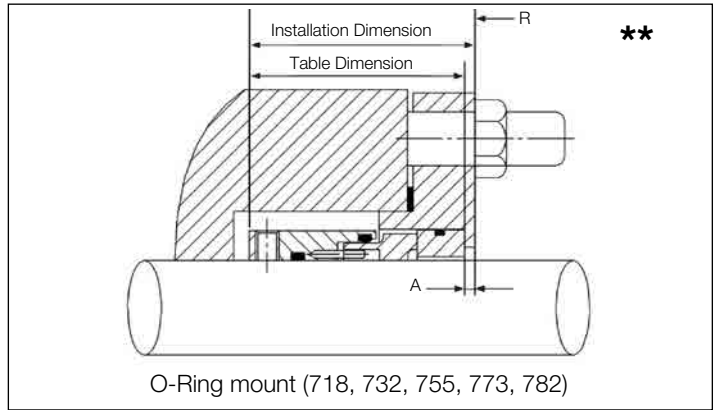
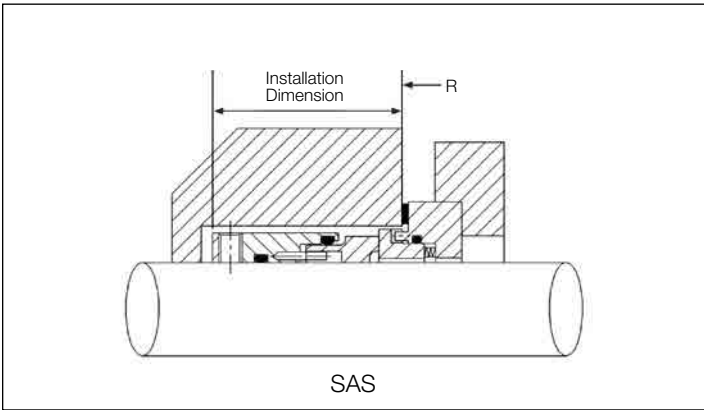
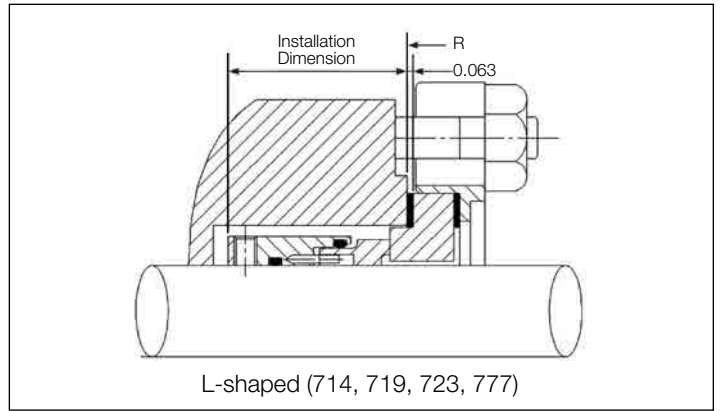
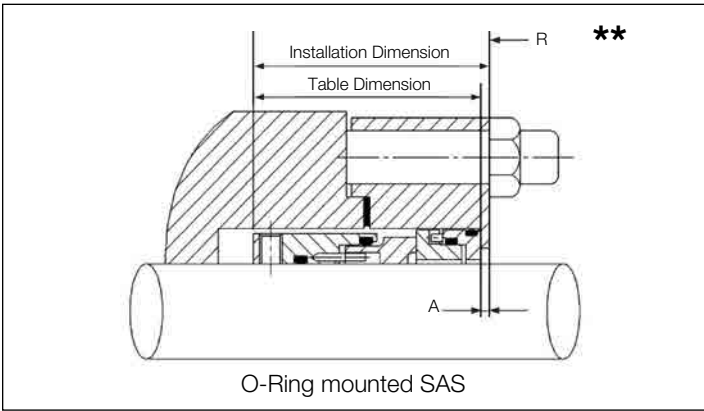

R = reference point

\*\*Installation dimension = Table dimension + "A"

\*Installation dimension = Table dimension - "F"

# DIMENSIONAL DATA

	Shaft	714	719	723	777	725	755	718	773	732	VDMA	SAS	SAS	D	E
											Seal Only	Gland			
891 – METRIC (all dimensions are in millimeters)	68				48.9									147	152
	70		49.2		48.9				60.4	60.4	59.4	44.4		148	152
	75		55.5		55.3			66.7	66.7	66.7	65.8	50.8		234	238
	80		55.5		55.3			70.7	70.7	70.7	66.3	50.8		236	240
	85		55.5		55.3				70.7		66.3	50.8		237	241
	90		55.5		55.3		63.5		70.7	70.7	66.3	50.8		239	243
	95				55.3		70.7	70.7	70.7	70.7	66.3	50.8	54	240	244
	100	55.5			55.3		70.7	70.7	70.7	70.7	66.3	50.8		242	246
	110				55.3						66.3	50.8		246	249
	120									111.9				351	356
	125													353	358
	130									111.9				354	360
	135													356	362
	140													357	362
	145													359	363
	150													361	364
	155										111.9			361	365
	160								111.9					363	366
	165													363	366
	170													364	367
175													365	368	
180													366	369	
185													366	369	
190													367	370	
195													368	371	
200								111.9					369	372	
880 – METRIC (all dimensions are in millimeters)	70		49.2		48.9				60.4	60.4	59.4	44.4		232	235
	75		49.2		48.9			60.4	60.4	60.4	59.4	44.4		234	237
	80		49.2		48.9			64.3	64.3	64.3	59.9	44.4		235	239
	85		49.2		48.9				64.3		59.9	44.4		237	240
	90		49.2		48.9				64.3	64.3	59.9	44.4		239	242
	95				48.9		64.3	64.3	64.3	64.3	59.9	44.4	47.6	240	243
	100	49.2			48.9		64.3	64.3	64.3	64.3	59.9	44.4		242	245
	110				48.9						59.9	44.4		245	249

D – Static O-Ring

E – Dynamic O-Ring

	Shaft	714	719	723	725	755	718	773	782	732	ORM/ SAS	Washer Mount		414	SAS	D	E
												No ADPT	ADPT				
891 – INCH (all dimensions are in inches)	2.750	2.19	2.19				2.63	2.63	2.63	2.63				2.19	2.25	232	236
	2.875	2.19	2.19			2.63	2.63	2.63	2.63	2.63	3.00				2.25	233	237
	3.000	2.19	2.19			2.63	2.63	2.63	2.63	2.63	3.00			2.19	2.25	234	238
	3.125	2.19	2.19				2.78	2.78	2.78	2.78				2.19	2.25	235	239
	3.250	2.19	2.19				2.78	2.78	2.78	2.78					2.25	236	240
	3.375	2.19	2.19			2.78	2.78	2.78	2.78	2.78				2.19	2.25	237	241
	3.500	2.19	2.19			2.78	2.78	2.78	2.78	2.78					2.25	238	242
	3.625	2.19	2.19						2.78	2.78					2.25	239	243
	3.750	2.19	2.19			2.78	2.78	2.78	2.78	2.78					2.25	240	244
	3.875	2.19					2.78	2.78	2.78	2.78						241	245
	4.000	2.19	2.19			2.78	2.78	2.78	2.78	2.78				2.25	242	246	
	4.125	2.19					2.78	2.78	2.78	2.78						243	247
	4.250	2.19				2.78	2.78	2.78	2.78	2.78				2.25	244	248	
	4.375	2.19	2.19			2.78	2.78	2.78	2.78	2.78				2.25	245	249	
	4.500	2.19				2.75	2.78	2.78	2.78	2.78				2.25	246	250	
	4.625					4.41	4.41	4.41	4.41	4.41						350	356
	4.750	3.81				4.41	4.41	4.41	4.41	4.41						351	356
	5.000						4.41	4.41	4.41	4.41						353	358
	5.250						4.41	4.41	4.41	4.41						355	360
	5.500					4.41	4.41	4.41	4.41	4.41						357	362
5.750						4.41	4.41	4.41	4.41						359	363	
6.000							4.41	4.41	4.41						361	364	
6.250					4.41		4.41	4.41	4.41						362	365	
6.500							4.41	4.41	4.41						363	366	
6.750								4.41	4.41						364	367	
7.000					4.41				4.41						365	368	
7.250					4.41										366	369	
7.500							4.41		4.41						367	370	
7.750															368	371	
8.000						4.41			4.63						369	372	
880 – INCH (all dimensions are in inches)	2.750	1.94	1.94				2.38	2.38	2.38	2.38				1.94	2.00	232	235
	2.875	1.94	1.94			2.38	2.38	2.38	2.38	2.38	2.75				2.00	233	236
	3.000	1.94	1.94			2.38	2.38	2.38	2.38	2.38	2.75			1.94	2.00	234	238
	3.125	1.94	1.94				2.53	2.53	2.53	2.53				1.94	2.00	235	238
	3.250	1.94	1.94				2.53	2.53	2.53	2.53					2.00	238	239
	3.375	1.94	1.94			2.53	2.53	2.53	2.53	2.53				1.94	2.00	237	240
	3.500	1.94	1.94			2.53	2.53	2.53	2.53	2.53					2.00	238	241
	3.625	1.94	1.94				2.53	2.53	2.53	2.53					2.00	239	242
	3.750	1.94	1.94			2.53	2.53	2.53	2.53	2.53					2.00	240	243
	3.875	1.94					2.53	2.53	2.53	2.53						241	244
	4.000	1.94	1.94			2.53	2.53	2.53	2.53	2.53				2.00	242	245	
	4.125	1.94					2.53	2.53	2.53	2.53						243	247
	4.250	1.94				2.53	2.53	2.53	2.53	2.53				2.00	244	247	
	4.375	1.94	1.94			2.53	2.53	2.53	2.53	2.53				2.00	245	249	
	4.500	1.94				2.53	2.53	2.53	2.53	2.53				2.00	246	249	
4.625					2.78	2.78	2.78	2.78	2.78						247	252	
4.750	2.19				2.78	2.78	2.78	2.78	2.78						248	252	

## CAUTIONS

These instructions are general in nature. It is assumed that the installer is familiar with seals and certainly with the requirements of their plant for the successful use of mechanical seals. If in doubt, get assistance from someone in the plant who is familiar with seals or delay the installation until a seal representative is available. All necessary auxiliary arrangements for successful operation (heating, cooling, flushing) as well as safety devices must be employed. These decisions are to be made by the user. The decision to use

this seal or any other Chesterton seal in a particular service is the customer's responsibility. Do not touch the mechanical seal for any reason while it is operating. Lockout or uncouple the driver prior to personal contact with the seal. Do not touch the mechanical seal while it is in contact with hot or cold fluids. Ensure that all the mechanical seal materials are compatible with the process fluid. This will prevent possible personal injury.

## OPERATING LIMITS

### Pressure Limits:

Depending on shaft size, speed and face combination:

#### 891

Down to 711 mm (28") Hg vacuum

Sizes 18 mm to 30 mm up to 21 bar  
( $\frac{3}{4}$ " to 1  $\frac{1}{4}$ " (300 psi)

Sizes 40 mm to 110 mm up to 42 bar  
(1  $\frac{3}{8}$ " to 4  $\frac{1}{2}$ " (600 psi)

Sizes 120 mm to 200 mm up to 28 bar  
(4  $\frac{3}{4}$ " to 8") (400 psi)

#### 880

Down to 711 mm (28") Hg vacuum

Sizes 18 mm to 30 mm up to 21 bar  
( $\frac{3}{4}$ " to 1  $\frac{1}{4}$ " (300 psi)

Sizes 40 mm to 200 mm up to 28 bar  
(1  $\frac{3}{8}$ " to 8") (400 psi)

### Temperature Limits:

To 205°C (400°F) with FKM.

To 150°C (300°F) with EPDM

-18°C to 260°C (0°F to 500°F) with FEPM

-30°C to 230°C (-20°F to 450°F) with FFKM

## RETURNS

### Returning Seals for Repair and Hazard Communication Requirements

Any mechanical seal returned to Chesterton that has been in operation, must comply with our Hazard Communication requirements.

Please scan the QR Code with your mobile device or go to our web page at [www.chesterton.com/Mechanical\\_Seal>Returns](http://www.chesterton.com/Mechanical_Seal>Returns) to obtain information required for returning seals for repair or seal analysis.



860 Salem Street  
Groveland, MA 01834 USA  
Telephone: 781-438-7000 Fax: 978-469-6528  
[www.chesterton.com](http://www.chesterton.com)

© 2015 A.W. Chesterton Company.  
® Registered trademark owned and licensed by  
A.W. Chesterton Company in USA and other countries.

FORM NO. EN36471 REV. 1

Chesterton ISO certificates available on [www.chesterton.com/corporate/iso](http://www.chesterton.com/corporate/iso)

PRINTED IN USA 8/15